

**INNOVATIVE METHODS IN SHEAR REINFORCEMENT OF REINFORCED  
CONCRETE BEAMS**Moayyad Al-Nasra<sup>\*1</sup><sup>1</sup>Department of Civil and Infrastructure Engineering, College of Engineering,  
American University of Ras Al Khaimah, AURAK,  
Ras Al Khaimah, UAE**ABSTRACT**

Shear Reinforcement of reinforced concrete members has been great challenge, especially for reinforced concrete beams. The sudden shear failure of reinforced concrete beams due to excessive shear forces made the design for shear reinforcement even more challenging. This type of failure is completely undesirable and it demands higher factor of safety. This pushed researchers to look for other alternatives. Several alternatives to the traditional shear reinforced will be introduced and discussed in this study. New concept of shear reinforced called swimmer bars shear reinforcing system is explored in this study. This new type of swimmer bars require no welding but perform as good as the welded swimmer bars. This study focuses on new and innovative type of swimmer bars. This new swimmer bars system used in this study is called three dimensional space swimmer bars system. This type of swimmer bars are proven to be effective in taking care of the shear forces in reinforced concrete beams. Also, this type of improved swimmer bars system improves on the shear failure mechanism of reinforced concrete beams. Several beams were prepared and tested in the lab. Three different types of beams were prepared; beams reinforced with the new swimmer bars system, beams reinforced with welded swimmer bars system, and beams reinforced with the traditional stirrups. The results of the tests are discussed and presented. The three dimensional space swimmer bars system is basically a reinforcing bar bent several times in the three dimensions forming special configuration along with its coupling swimmer bar. This configuration makes the shear reinforcement system act as plane-crack interceptor rather than linear bar-crack interceptor. This new type of shear reinforcement is proven to be effective and economical. Flexural cracks are monitored throughout the test. The deflection of the beams under gradually increasing load is also measured and presented in this study

**Keywords:**

Space, Swimmer bar, Deflection Shear, Crack, Stirrup

**INTRODUCTION**

The structural design codes usually emphasize on safety as a first priority that should be taken into consideration when designing steel and concrete structures. The sudden failure mode requires higher factor of safety. The design engineer has to make sure that the mode of failure is acceptable and gives enough warning before failure. The shear failure is not one of the desirable modes of failures and should be avoided. Reinforced concrete beams are one of the common structural elements that carry transversal loads mainly by flexure and shear. The common design approach is to design the beam for flexure then design the beam for shear. The available design codes emphasizes on the ductile flexural failure by reducing the amount of steel reinforcement in the tension area, in order to make sure that the longitudinal tension bars yield first. While the design for shear focuses on providing enough shear resistance exceeding the applied shear force by a margin of safety factor. The shear resistance comes from two different sources; the concrete and the shear reinforcing bars. The concrete shear strength depends on the cross section of the beam, and the concrete compressive strength. Large applied shear force requires shear reinforcing bars of large diameter placed at closer spacing.

The design codes provide factor of safety enough to make sure that the beam will survive applied loads during its expected service life. Punching shear in slabs is considered one of the governing factors in the design of flat slabs and raft foundations [1]. Several researchers provided some solution for shear reinforcement including swimmer bars [2]. These swimmer bars added significant shear resistance [3]. Creative pyramid swimmer bars were used [4]. The results were compared with the traditional slab reinforcement.

Beams subjected to large shear force exhibit diagonal cracks initiated near the supports. These diagonal cracks have the tendency to widen and propagate moving toward the center of the beam. These cracks are proven to propagate at a faster rate compared with the bending flexural cracks. Steel stirrups, which are shear reinforcing

bars, are placed perpendicular to the longitudinal flexural bars and used to reduce the shear cracks. Several alternatives to the traditional stirrups were explored including U-links swimmer bars and spliced swimmer bars [5, 6].

Experimental research showed that the effective depth of reinforced concrete beams is not a sensitive parameter to the shear strength of the beam [7]. The shear strength was the target of experimental investigations as related to several parameters including the effective depth. Other experimental research utilized the use of bent-up bars to improve the shear performance of reinforced concrete beams [8]. The experimental results showed that the bent-up bars have the potential to improve the shear performance of reinforced concrete beams [9]. The use of bent-up bars is a matter of choice. The bent-up bars used to be common practice in the past, but its popularity decreased lately for practical reasons.

Swimmer bars were used effectively to improve the shear strength of the reinforced concrete beams [10, 11]. Several attempts to replace the welds in the swimmer bars due to the uncertainty in the performance of the welds in the log run were explored [12,13]. Investigating the use of several types of swimmers bars were explored and proven to be comparable to the performance of the welded swimmer bars [14, 15]. Cost analysis studies lead to optimizing the use of the swimmer bars as an alternative solution for the shear reinforcement [16]. Bar size and bar spacing were the focus of many research topics in this area [17]. The main focus of these studies was to improve the shear resistance and to reduce cost. Researchers studied the possibility of changing the shape of the reinforced concrete beams and slab in order to reduce the internal stresses leading to substantial reduction in steel reinforcement [18, 19]. The shear performance can also be improved by improving the shear resistance of the concrete by optimizing the concrete mix design [20].

In this study three groups of beams were prepared. The first group is regular beams reinforced with ordinary standard stirrups. The second group used welded swimmer bars as shear reinforcement. The third group used new type of space swimmer bars. The beams in the third group are reinforced with the new space swimmer bars. The results of this group are compared with the beams reinforced with stirrups and the beams reinforced with the welded swimmer bars. This study covers also the swimmer bar spacing in order to study the effect of increasing the shear reinforcement provided by the swimmer bars on the beam performance in shear. Three different values of swimmer bar spacing were used to study the shear performance of the reinforced concrete beams. Large longitudinal flexural reinforcing bars were added at the bottom of simply supported beams to make sure that the beams will not fail by flexure in order to shift the focus toward the shear strength of these beams. The space swimmer bars can be easily constructed and assembled without the need for welding or special fabrication. The space swimmer bars can be spliced with the longitudinal flexural bars in order to add rigidity to the swimmer bars system. The speed of building the steel cage is also one of the major advantages of the space swimmer bars.

According to the ACI Code provision for shear design, the design of beams for shear is to be based on the following relation [21]:

$$V_u < \phi V_n \quad (1)$$

Where,  $V_u$  is the total factored shear force applied at any given section in the beam.

$$V_n = V_c + V_s \quad (2)$$

Where,  $V_n$  is the nominal provided shear strength,  $V_c$  is the concrete shear strength.  $V_s$  can be calculated as follows

$$V_s = (1/s) (\phi A_v f_{ys} d) \quad (3)$$

and for inclined bars

$$V_s = (1/s) (\phi A_v f_{ys} d) (\sin \beta + \cos \beta) \quad (4)$$

Where,  $A_v$  is the area of one stirrup,  $\beta$  is the angle of the shear reinforcing bars with the horizontal,  $S$  is the shear reinforcing bar spacing, and  $f_{ys}$  is the yield strength.

The nominal concrete shear strength can be expressed in it simplified form as follows

$$V_c = 0.167 \lambda (b_w d) \sqrt{f_c} \quad (5)$$

Where:  $b_w$  and  $d$  are the section dimensions, and  $\lambda = 1.0$  for normal weight concrete.

#### SWIMMER BARS

The swimmer bars used in this study are modified swimmer bars compared to the traditional swimmer bars. A swimmer bar is, in its traditional form, an inclined steel bar where both ends are bent to be in line with the longitudinal flexural bars. These bars are usually welded together in order to add stiffness to the steel shear reinforcing system. This added rigidity helps the swimmer bars to act as plane-cracks interceptor. Figure (1) shows typical standard swimmer bars. Many different configurations can be derived from this standard shape, including adding intermediate swimmer bars and adding cross-bracings. Figure (2) shows the new space swimmer bars used in this research. Figure (3) shows two space swimmer bars assembled together as couple. The space swimmer bars should be accurately bent with appropriate angles in order to splice these bars effectively with the longitudinal flexural steel bars. Each two space swimmer bars are assembled together forming a complete loop. These two swimmer bars are wired together initially as shown in Figure (3).



*Fig. 1: Typical welded swimmer bars*

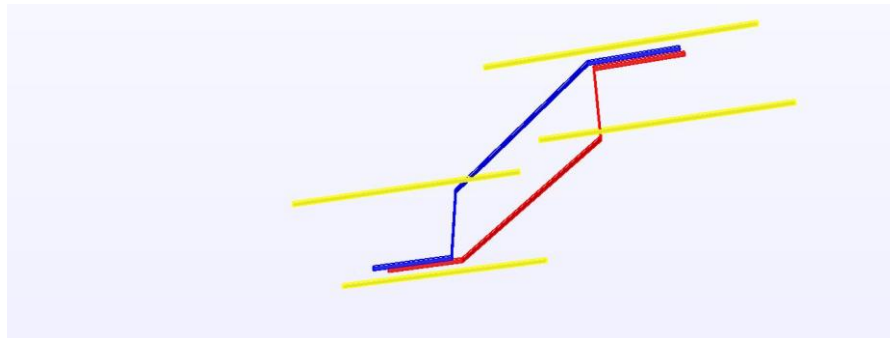

*Fig. 2: Coupled space swimmer bars along with the longitudinal bars*



*Fig. 3: Assembled space swimmer bars loop.*

### TESTED BEAMS

Several beams were prepared to be tested by flexural bending due to gradually increasing point loads. The experimental test of beams for the shear strength is mainly to study the effect of the use of the special type of swimmer bars called here space swimmer bars. The results of the shear strength test of beams made with the space swimmer bars are compared with the results of beams made with welded swimmer bars, and the results of the beams made with regular stirrups. The swimmer bars spacing is also a factor in this experimental research. The test focuses on the effect of the swimmer bar spacing on the shear strength of the beam subjected to two point loads. Deflection at the mid-span of the beam is also taken into consideration given all other variables. The cracks, especially the diagonal shear cracks, will be monitored as the applied load increases.

The longitudinal tension flexural steel reinforcement is designed such that the beam fails by shear, since the focus of this study is on the shear performance of reinforced concrete beams. The mode of failure is, by design, shear failure at the beam supports. The increase in the beam strength is the reflection of the increase in the shear strength of that beam. Top longitudinal steel reinforcement is used here, making the beams doubly reinforced beams with compression steel at the top part of the beams. Many parameter were fixed in this study including the beam dimensions, and the concrete compressive strength. The shear span over the effective depth is calculated to be 2.5 for all of the tested beams. The concrete compressive strength is measured according to ASTM C 192-57. Concrete cubes were prepared and tested on the 28<sup>th</sup> day to measure the concrete compressive strength of the concrete used in this study. The average compressive strengths of three cubes is considered here at the 28<sup>th</sup> day of the concrete age. The average concrete compressive strength is calculated to be 29.87 MPa. The variation between the average concrete compressive strength and the three tested cubes does not exceed 0.5 MPa.

The total length of the beam mold is 2000 mm. The cross-sectional area is 200 mm width by 250 mm depth. All beams are made of the same typical dimensions. The effective length of the beam is taken to be 1800 mm, giving 100 mm space at either supports. All beams were reinforced with 4  $\Phi$  16 mm as bottom steel, and 3  $\Phi$  14 as top steel. The control beam used here is the beam with standard stirrups. This beam is also reinforced for shear with 10  $\Phi$  8 mm standard stirrups spaced at 60 mm in the two shear sides of the beam. The swimmer bars used as alternative to the standard stirrups are of  $\Phi$  10 mm. These swimmer bars are either welded or bent. Figure (4) shows typical steel reinforcement detail used in this study. The figure shows the location of the swimmer bars at the left side and at the right side of the beam for a distance of 550 mm. The angle of the sloped swimmer bar " $\beta$ " is kept constant at a value of 37 degrees measured with respect to the horizontal longitudinal bars.

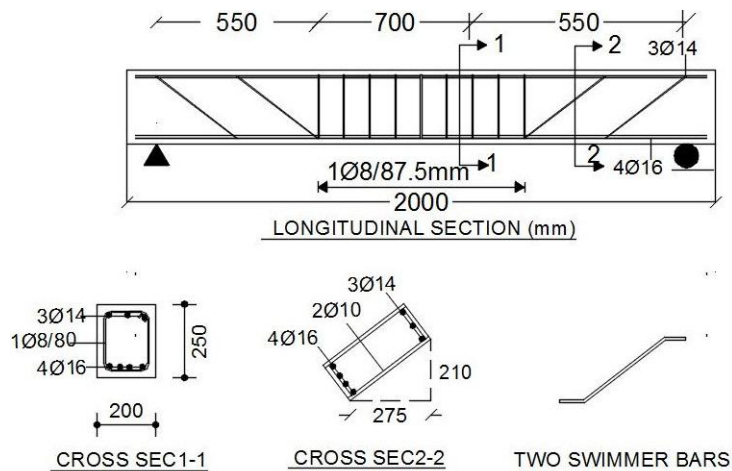

*Fig. 4: Typical steel reinforcement used in this study*

#### TEST PROCEDURE

The effect of the use several types of swimmer bars is the focus of this study. A total of seven main beams were prepared to be tested in this study. The first is reinforced with standard stirrups for shear and is designated as the control beam. The second group of beams were reinforced with welded swimmer bars. The welded swimmer bars were placed at three different values of bar spacing. The third group is reinforced with space swimmer bars using the same values of bar spacing as the welded swimmer bars system. The beams were painted with white paint in order to make it easier to detect and follow the progress of the cracks. Marks were placed at significant points at the beams to show the location of the applied loads and the location of the supports. Sufficient flexural steel is used for all beams to make sure that the beam failure is controlled by shear failure. The beams were loaded with two concentrated point loads of the same value located at 550 mm for either support. Figure (5) shows the typical test setup used in this study. The figure shows the location of the applied loads. Figure (6) shows the experimental set up used in this study. The load is applied by a loading jack against rigid base member. This applied load is gradually increased until the beam failure by shear is reached. The deflection at the mid-span of the beam and the cracks were monitored throughout the testing procedure.

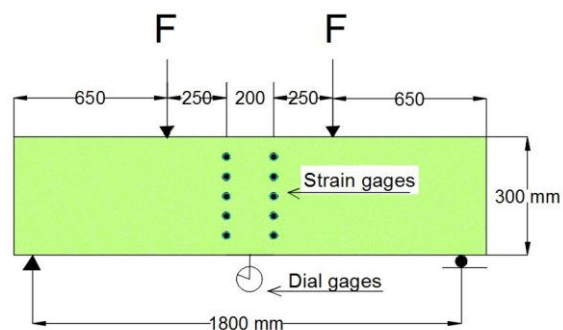

*Fig. 5: Test set up drawing*

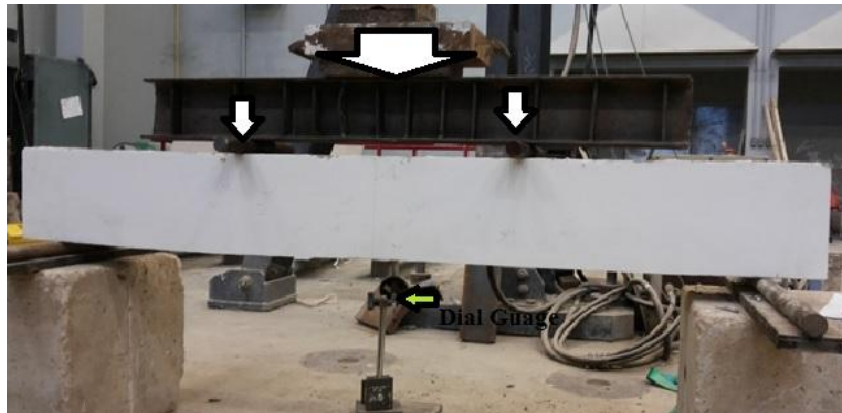

*Fig. 6: Typical experimental set-up*

### TEST RESULTS

The beams prepared for the test were painted, labeled and marked. Special attention is given to the propagation of the concrete cracks through the test. The applied load is increased gradually at a rate just enough to take readings, and observe the progress of the concrete cracks. The cracks became visible initially at a load of 60 kN. The initial crack starts at the support with smaller angle. Soon after, other cracks become visible and start moving toward the center of the beam at larger angles. The flexural crack starts at approximately 90 degrees near the mid-span. Figure (7) shows the typical shear failure of a beam reinforced with space swimmer bars. The initial and major shear crack start at angle of approximately 30 degrees measured with respect to the horizontal line. The following shear cracks start at higher angle. Soon after the major shear crack becomes visible bending cracks start to appear at the mid-span of the beam. The width of the shear cracks is visibly larger than the width of the flexural cracks. The shear cracks propagate at a faster rate than the flexural cracks.



*Fig. 7: Typical shear failure.*

Figure (8) shows the shear strength of beam reinforced with swimmer bars. The welded swimmer bars exhibit a slight increase in shear strength especially at high range of bar spacing. When the spacing of the swimmer bars gets smaller the difference in shear strength between the welded swimmer bars and the space swimmer bars becomes negligible. Figure (9) shows the shear strength of three types of beams of equivalent shear reinforcement steel by weight. The figure shows that the use of the swimmer bars as shear reinforcement system is more efficient than the regular stirrups. The welded swimmer bars system showed an improvement in the beam shear performance of 49% over the beams reinforced with standard stirrups. The space swimmer bars system also showed a comparable improvement of 46% over the beams reinforced with standard stirrups.

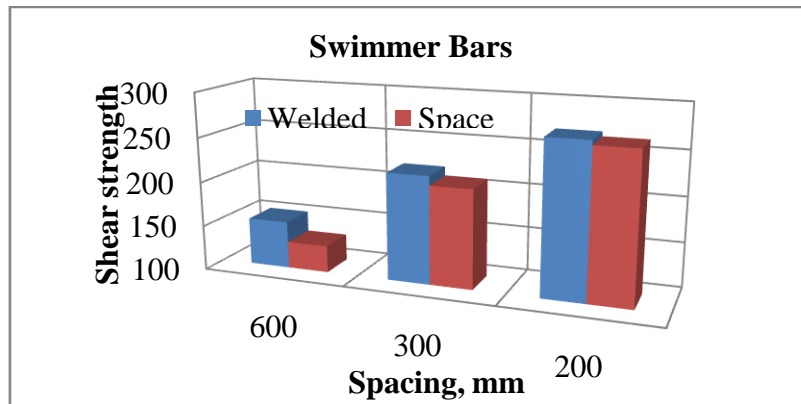

Fig. 8: Shear strength of beams reinforced with swimmer bars

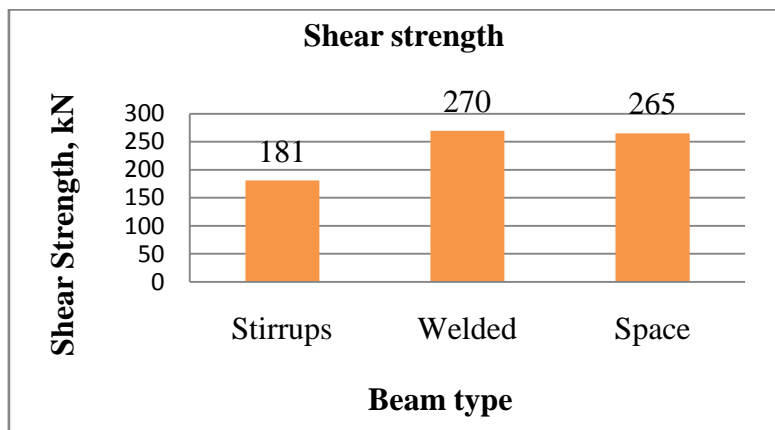

Fig. 9: Shear strength of beams of similar shear reinforcement by weight.

Figure (10) shows the beam deflection of the three different types of beams at failure. This shows that the rigidity of the beams reinforced with swimmer bars for shear is higher than the rigidity of the beams reinforced with the standard stirrups. Also it can be seen from this figure the rigidity of the beams reinforced with welded swimmer bars for shear is very similar to the rigidity of the beams reinforced with the new space swimmer bars system.

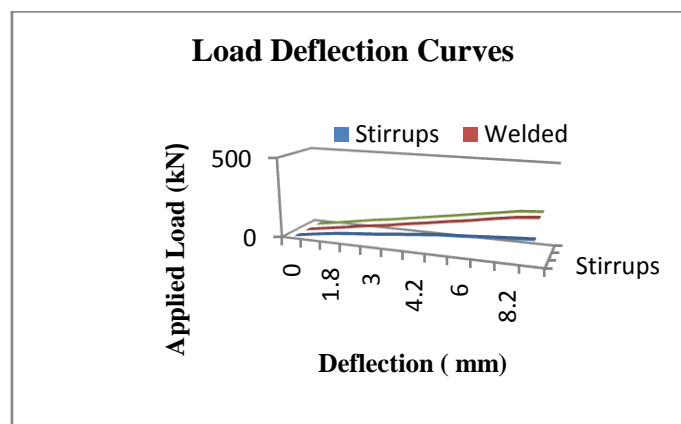

Fig. 10: Load deflection relation of the three types of beams before failure

Figure (11) shows the relationship between the shear strength of beams reinforced with space swimmer bars for shear and the reciprocal of the swimmer bars spacing. The following equation is derived for the swimmer bars of 10 mm diameter. This equation shows the relationship to be linear relating the bar spacing with the shear strength as shown equation (6). Similar relationships can be derived for the other bar diameters.

$$V_s = (37500/S) + 80 \quad (6)$$

Where,

$V_s$  = Shear strength in kN

S = Bar spacing in mm

The coefficient of determination of this equation denoted as  $R^2$  is 0.995 which reflects the accuracy of the correlation. The other parameters affecting the value of the shear strength are fixed in this case, including the area of steel bars, beam depth, steel strength, and the angle  $\beta$ . The numerical value 37500 includes all of these parameters.

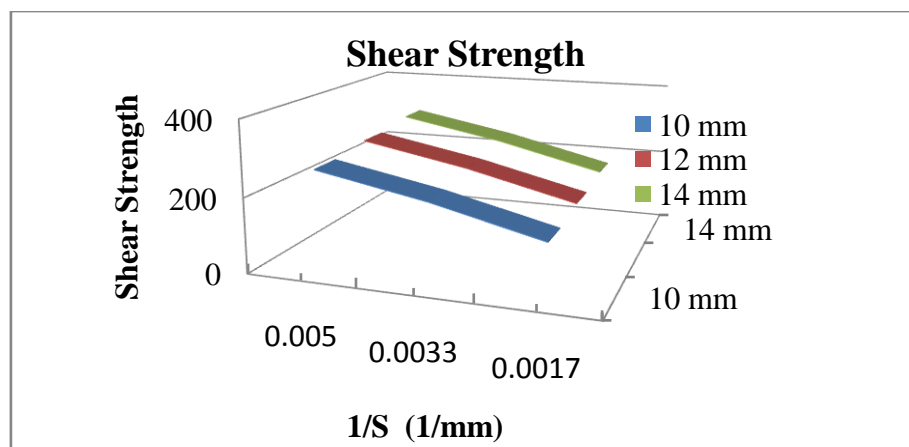

Fig. 11: Shear strength-bar spacing relationship of space swimmer bars system.

### CONCLUSION

The modified space swimmer bars system performed very well compared with the other types of swimmer bars. This type of swimmer bars do not need to be welded in order to provide lateral and torsional stiffness needed to make the swimmer bars system act as plane shear interceptor. The performance of the new space swimmer bars is proven to be as good as the welded swimmer bars in terms of shear strength, rigidity and overall beam deflection. In general, the use of the swimmer bars in reinforced concrete beams improves the shear strength by approximately 50% compared with the performance of the beams reinforced with the traditional stirrups. The new space swimmer bars system can be easily constructed on the site. The construction speed of the space swimmer bars system is relatively high compared with the welded swimmer bars. Overall, the new space swimmer bars system is characterized by its simplicity, its efficiency, and its cost effectiveness. This new type of space swimmer bars system is also considered safer compared to the welded swimmer bars system due to the uncertainty of the performance of the weld in the long run.

### REFERENCES

- [1] Al-Nasra, M.M.; and Wang, L.R.L., *Parametric Study of Slab-On-Grade Problems: Due to Initial Warping and Point Loads*, ACI Structural Journal, Vol. 91 No. 2, 1994.
- [2] Duweib, I; Al-Nasra, M; Najmi, A., *Investigating the Use of Swimmer Bars as Punching Shear Reinforcement of Reinforced Concrete Flat Plates*, International Journal of Engineering Research and Industrial Applications, Vol. 6, No. 1, PP 127-139, ISSN 0974-1518. February 2013.
- [3] Al-Nasra, M.; Najmi, A; Duweib, I., *Effective Use of Space Swimmer Bars in Reinforced Concrete Flat Slabs*, International Journal of Engineering Sciences and Research Technology, Vol. 2 No. 2, ISSN: 2277-9655, 2013
- [4] Al-Nasra, M; Duweib, I; Najmi, A., *The Use of Pyramid Swimmer Bars as Punching Shear Reinforcement in Reinforced Concrete Flat Slabs*, Journal of Civil Engineering Research, Vol. 3, No. 2, 2013, PP 75-80. DOI: 10.5923/J.JCE.20130302.02, March, 2013

- [5] Al-Nasra, M; Asha, N., *The Use of Bolted U—Link Swimmer Bars in the Reinforced Concrete Beams*, International Organization of Scientific Research, Journal of Engineering (IOSRJEN), Vol. 3 , Issue 10 , Version 5, ISSN Print: 2278-8719, ISSN Online: 2250-3021, DOI: 10.9790/3021-031052632, ANED: 0.4/3021-031052632, Pages 26-32, October, 2013.
- [6] Al-Nasra, M.; Asha, N., *Investigating the Use of Spliced Swimmer Bars as Shear Reinforcement in Reinforced Concrete Beams*, International Organization of Scientific Research, Journal of Engineering (IOSRJEN), Vol. 05 , Issue 02 , Version 02, ISSN Print: 2278-8719, ISSN Online: 2250-3021, DOI:- 05224754, ANED: 0.4/3021- 05224754, ESCI-MML 3021-0502-4754, Pages 47-54, Feb, 2015
- [7] Sneed L.; Julio A., *Effect of Depth on the Shear Strength of Concrete Beams without Shear Reinforcement*, USA Portland and cement Association, 2008.
- [8] Hamid N., *The Use of Horizontal and Inclined Bars as Shear Reinforcement* , Master Thesis, University of Technology , Malaysia, 2005.
- [9] Najmi, A.; Al-Nasra, M.; Asha, N., *Improved Shear Performance of Bent-up Bars in Reinforced Concrete Beams*, International Journal of Engineering Sciences and Research Technology, Vol. 2, Issue 5, ISSN: 2277-9655, pages 1264-1268, May 2013
- [10] Al-Nasra, M.; Asha, N.; Najmi, A.; Abulebdeh, T. , *The use of swimmer bars as shear reinforcement in reinforced concrete beam*, American Journal of Engineering and Applied Science, Vol. 6, Issue 1, ISSN Print: 1941-7020, ISSN Online: 1941-7039, DOI: 10.3844/ajeassp.2013.87.94, PP. 87-94, March 15, 2013.
- [11] Al-Nasra, M., *Shear Failure Investigation of Reinforced Concrete Beams with Swimmer Bars*, Journal of Civil and Construction Technology, Vol. 4, No. 2, PP. 56-74. DOI: 10.5897/JCECT2013.0251, ISSN 2141-2634-2013 Academic Journals, 2013
- [12] Al-Nasra, M.; Asha, N.; Najmi, A., *Investigating the Use of Swimmer Bars as Shear Reinforcement in Reinforced Concrete Beams*, International Refereed Journal of Engineering and Sciences (IRJES), Vol. 2, Issue 4, Pages 40-49, ISSN (online): 2319-183X, ISSN (print): 2319-1821, April 2013.
- [13] Al-Nasra, M.; Asha, N., *Shear Reinforcements in the Reinforced Concrete Beams*, American Journal of Engineering Research (AJER), Vol. 2, Issue 10, ISSN online: 2320-0847, ISSN print: 2320-0936, ANED: 30.0847/0210191199, Pages 191-199, October 2013.
- [14] Al-Nasra, M., *Investigating alternatives in Shear reinforcements in the Reinforced Concrete Beams*, International Journal of Civil and Structural Engineering- IJCSE, SEEK, Volume 2, Issue 2, ISSN : 2372-3971, Pages 168 – 172, October 2015.
- [15] Al-Nasra, M., *The Use of Recycled Steel Bars as Shear Reinforcement Swimmer Bars in reinforced Concrete Beams*, International Journal of Engineering and Advanced Technology (IJEAT), Blue Eyes Intelligence Engineering publishing company, Volume 5, Issue 2, ISSN: 2249-8959, Pages 42-47, December 2015.
- [16] Asha, N.; Al-Nasra, M.; Najmi, A., *Optimizing the Use of Swimmer Bars as Shear Reinforcement in the Reinforced Concrete Beams*, International Journal of Civil and Structural Engineering, Vol. 3, No. 2, Pages 313-320, ISSN 0976-4399, DOI: 10.6088/ijcser.201203013030, 2012.
- [17] Al-Nasra, M., *The Use of Space Swimmer Bars as Shear Reinforcement in Reinforced Concrete Beams*, IJET International Journal of Engineering and Technology, ISSN (Print) 2319-8613, ISSN (Online) 0975-4024, DOI: 10.21817/ijet/2017/v9i2/170902235, Vol. 9, No. 2 April 2017
- [18] Al-Nasra, M.; Daoud, M., *Effect of the Aspect Ratio on the Transitional Structural Behavior between Plates and Shells*, International Journal of Applied Engineering Research, ISSN 0973-4562. Volume 11, Number 21 (2016), pp. 10634-10639, 2016.
- [19] Al-Nasra, M., *Finite Element Investigation of Dome-Like Structures*, ARPN Journal of Engineering and Applied Sciences, ISSN 1819-6608, Vol. 12, No. 11, Pages 3445-3450, June 2017.
- [20] Al-Nasra, M., *Optimizing the Use of Sodium Polyacrylate in Plain Concrete*, International Journal of Engineering Research and Applications (IJERA), Vol. 3, Issue 3, ISSN: 2248-9622, www.ijera.com, , pages 1058-1062, May-Jun 2013.
- [21] ACI 318-11, 2014. Building Code Requirements for Structural Concrete Commentary, American Concrete Institute, 2014.