

**MECHANICAL FLEXIBLE COUPLINGS FOR TORQUE TRANSMISSION
BETWEEN TWO UNITS**

Sasko Milev^{*1}
Darko Tasevski²
Mevludin Shabani³
Zoran Dimitrovski⁴
Blaze Rizov⁵

^{*1,4,5} Faculty of Mechanical Engineering, Goce Delcev University, Stip, North Macedonia
Krste Misirkov, 10A, 2000, Stip; email: ¹sasko.milev@ugd.edu.mk ; ⁴zoran.dimitrovski@ugd.edu.mk

²Faculty of Mechanical Engineering, Ss Cyril and Methodius University in Skopje, North Macedonia

³Faculty of Mechatronics, University of Business and Technology, Prishtina, Kosovo;
email: mevludin.shabani@ubi-uni.net

ABSTRACT

Mechanical flexible couplings transmit torque between two shafts and simultaneously eliminate vibrations and shock loads that may occur during machine operation. These couplings have ability to adapt to parallel, angular and axial movements of the shafts. In certain cases, flexible couplings can be used as "fuses" for the components when subjected to torque loading. There are many types of mechanical flexible couplings for torque transmission. One of the most commonly used categorizations group mechanical flexible couplings into: gear couplings, chain couplings, grid couplings, slider couplings, spiral couplings, and bellows couplings. Each type of coupling has a specific maximum tolerance for misalignment.

Keywords:

Flexible couplings, Torque transmission, Gear couplings, Chain Couplings, Grid Couplings, Slider Coupling, Spiral Couplings, Bellows coupling.

INTRODUCTION

In every field of engineering, safety and high performance of machine parts during operation are very important. Regarding the quality of manufacture and the coupling mode operation strict criteria are applied in practice. The primary purpose of couplings is torque transmission from one to another shaft. Couplings can also be used to connect two units, for example a motor and a generator, or to form longer shafts when two or more multiple shafts with standard lengths are connected. Additionally, couplings can transmit axial thrust loads between machines and any axial growth that may occur as a result of high temperatures. Couplings can be rigid or flexible. When two shafts are properly connected with a rigid coupling, they operate as a single shaft. Rigid couplings do not allow relative movement between the driving and driven parts and are primarily used in vertical systems. Flexible couplings are used to connect two axially positioned shafts, to transmit torque without slipping and to compensate for angular, parallel or axial misalignments. Depending on the design, flexible couplings can also provide vibration damping or act as a "fuse" in case of torque overloading. For these reasons, flexible couplings have a much broader application compared to rigid couplings.

MECHANICAL COUPLINGS

A coupling is a mechanical assembly or subassembly that serves to connect two shafts (driving and driven), a shaft with a transmission element (gear, pulley, etc.), as well as an immediate kinematic and dynamic connection between separate parts of machines (electric motor - pump, motor - gearbox, etc.) with the purpose of transmitting torque. In addition to the primary purpose of torque transmission, it performs other important functions: compensation for the detrimental influence of non-coaxial shaft connections, damping vibrations and impacts that may occur during operation, protecting elements from overloading, quick connection and disconnection of connected elements etc. Considered as the source of energy, the coupling should be light weighting and installed near the bearing. When dealing with a high number of revolutions, it should be statically

and dynamically balanced. According to the principle of transmitting torque, couplings are divided into few groups: mechanical, hydraulic, pneumatic, and electromagnetic. Mechanical couplings, based on the possibility of engagement and disengagement during operation, are classified as: continuously engaged, selectively engaged and disengaged, and automatically engaged and disengaged (self-engaging) [1],[2].

During the calculation of couplings, the maximum torque occurring during the operation of the coupling is used. If it is possible to determine the maximum torque (by assessing dynamic and potential overloads), it is taken as the relevant (calculative) parameter.

In other cases, the maximum torque T_{max} is determined using the drive factor of unevenness, denoted as K_A ($T=P/\omega$, P is the power transmitted by the coupling, and ω is angular velocity):

$$T_{max}=T \cdot K_A \quad (1)$$

The moment that the coupling reliably transmits T_s represents the ratio of the moment at which the most critical part of the coupling fractures and the safety factor (S). This moment should be greater or, in extreme cases, equal to the maximum moment (the relevant moment for calculation) (Fig.1):

$$T_s = \frac{T_m}{S} \geq T_{max} = T * K_A \quad (2)$$

S – safety factor ($S=2\div 3$); T_m [Nm] - the moment at which the coupling experiences fracture or failure

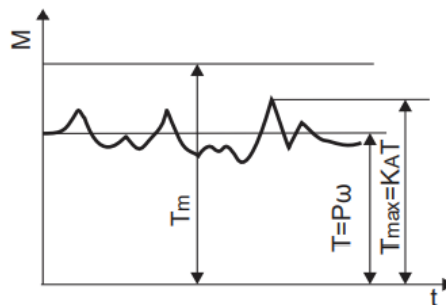

Fig. 1: Diagram of the Coupling Moment

The majority of today used couplings fall into the category of continuously engaged couplings. A key characteristic of these couplings is that they are continuously engaged, maintaining a constant connection between the joined elements, except during repairs or downtime. Depending on their construction's ability to dampen shocks during the transmission of torque, mechanical couplings are classified as rigid and flexible couplings.

Rigid couplings are used for shafts whose position is strictly aligned and when there are no impacts during operation. Compared to flexible couplings, rigid couplings have limited applications. These couplings lack the ability to compensate for misalignment between shafts and are therefore used where the shafts are already precisely laterally and angularly aligned. Rigid couplings are typically applied in machines that involve vertically oriented driving components. They transmit not only the rotational movement from the driving part (usually an electric motor) to the rotating element but also any axial displacement (up or down) that occurs between equipment parts. When using such couplings, due to their stiffness, the equipment must be precisely aligned, and any deviation cannot be accepted. Rigid couplings are often entirely made of metal components. This allows the coupling to operate in environments with high temperatures, high speeds, and significant driving force. Due to their simple design, rigid couplings, in general, are capable of transmitting greater power compared to flexible couplings of similar size.

Flexible couplings. In many cases where rigid couplings are used, the alignment of the driving and driven shafts is not perfect, resulting in potential damage to the motor or the coupling. To prevent such damage, flexible couplings are applied. Flexible couplings are typically used for transmitting torque from one shaft to another when exist a slight misalignment between the two shafts. These couplings can be used with various degrees of angular misalignment, up to 1.5°, and some non-coaxial offset between the shafts. They can protect the components of the driving and driven shafts, such as bearings, from the detrimental effects of vibrations, impact loads, and thermal expansion [3]. Depending on the material used for their components, flexible couplings can be metallic or elastomeric. Metallic types of couplings use freely mounted parts that roll or slide against each other, or stationary parts that flex to accommodate the coaxial misalignment of the shafts. Elastomeric types

gain flexibility from resilient, non-moving elastic or plastic elements that transmit the torque. Flexible couplings with twists, which have industrial applications, come in various constructive designs based on their functional roles and the requirements they must meet. These requirements differ not only in the dimensions of the constructive design but also in the shape of the elastic element. Flexible couplings are used in a wide range of machinery, including compressors, pumps, generators, winches, cranes, conveyors, reciprocating engines, as well as in the metallurgical and mining industries [4],[5].

Depending on the need for lubrication, there are flexible couplings with and without lubrication. Couplings that operate with lubrication achieve flexibility through loose parts that roll or slide against each other, while those without lubrication gain flexibility through the coiling of the metal component itself. Lubricated couplings are usually less expensive but require periodic maintenance. Non-lubricated couplings are generally more expensive, require minimal maintenance, and theoretically have an "infinite service life" since there is no direct metal-to-metal contact. In the group of couplings that require lubrication, gear couplings, chain couplings, grid couplings, and slider block couplings fall. The primary reason for defects in these couplings is wear (metal-to-metal contact), meaning that overloads from the torque and inadequate lubrication shorten the working life of the coupling.

Flexible couplings that operate without lubrication include spiral couplings and disc couplings. These couplings theoretically have an infinite service life, assuming that loads and coiling of the metal material remain within the limits of its mechanical durability (Overloading this type of coupling, whether continuous torque or cyclic forces due to misalignments, results in material fatigue). The misalignments that flexible couplings must accommodate can be parallel, angular, and axial. Figure 2 illustrates the different types of misalignments and changes in the position of the end of the shaft that may occur [6].

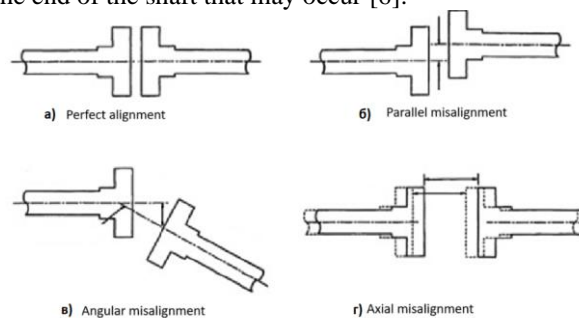

Fig. 2: Types of Shaft Misalignments

Parallel misalignment occurs when the two shafts that need to be aligned have parallel but displaced central lines. Angular misalignment represents a condition where there is a difference in the inclination of one shaft (usually the movable machine) relative to the inclination of the shaft of the other machine (usually the stationary machine). In a state of axial misalignment, the shafts move apart or come closer to each other. The most common cause of this type of misalignment can be the thermal expansion of the shafts. There are several reasons why misalignments can occur in shafts:

Over time, the base plate may settle into a lower position, causing gradual misalignment. The initial high torque generated during motor startup can cause the aligned shafts to shift. Thermal expansion, which can cause one part to move proportionally in relation to another part of the machine. Mechanical flexible couplings, depending on their construction and operation, can be categorized into: gear couplings, grid couplings, chain couplings, slider block couplings, spiral couplings and bellows couplings [7],[8].

GEAR COUPLINGS

One of the most commonly used types of couplings for power transmission are gear couplings. As shown in Fig.3, these couplings consist of two hubs with external teeth that engage the internal teeth of a one-piece (continuous) or two-piece sleeve (sleeve with a flange). The torque is transmitted from one hub to the sleeve and then to the other hub of the coupling. These couplings accommodate axial movement of the shafts (toward the inside or outside) as the teeth of the hub easily slide along the teeth of the sleeve without affecting the operation of the coupling.

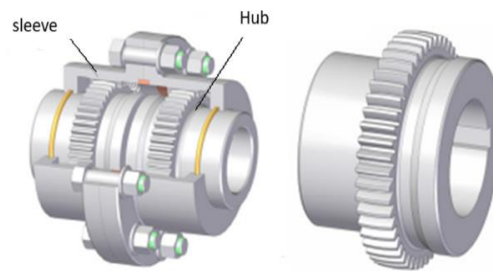

Fig. 3: a) Gear Coupling b) Flange from Gear Coupling

A typical defect in gear couplings is surface fatigue, manifested as the formation of pits, which can be prevented by limiting the contact pressure. There is always an angular misalignment between the surfaces of the coupling at any given moment. To determine the contact pressure, it is necessary to know the location of the current contact point and the principal deformations at that point [9].

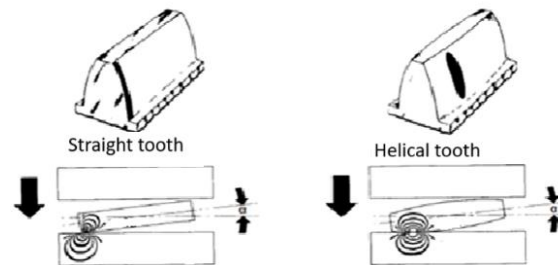

Fig. 4 : Straight and Helical Gears

As shown in (Fig.4), when using straight teeth on the hub, there is a significant concentration of loading during misalignment of the hubs and the sleeve. As misalignment increases, a larger portion of the load is borne by the edges of the teeth, resulting in premature wear and potential coupling defects. In the case of helical teeth, the tooth profile resembles a segment of a helix. Under the same operating conditions, helical teeth provide larger contact surfaces between the teeth of the hub and the sleeve. The increased contact surface leads to reduced stress between the teeth. Additionally, the rounded edges of the helix prevent the sharp square edges of the tooth from cutting into the material, avoiding coupling jamming.

Gear couplings designed for use with vertical shafts consist of a vertical set that holds the sleeve in a given position (Fig.5).

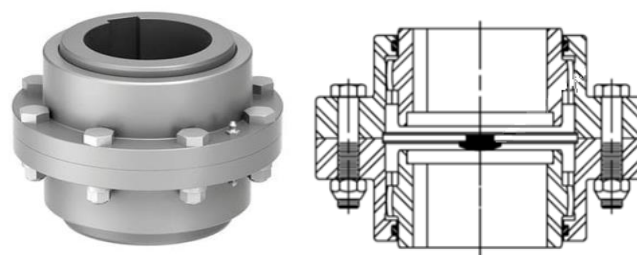

Fig. 5 : Vertical Type Gear Coupling

For gear couplings with helical tooth shapes, the maximum allowable angular misalignment is between 0.5° and 1.5° . The values for the maximum allowable parallel misalignment are recorded in a table as prescribed by the manufacturer and depend on the size of the coupling. The value for the maximum misalignment also depends on the operating speed (number of revolutions per minute). For higher speeds, the permissible misalignment value is smaller. The sleeve can be either one-piece or two-piece.

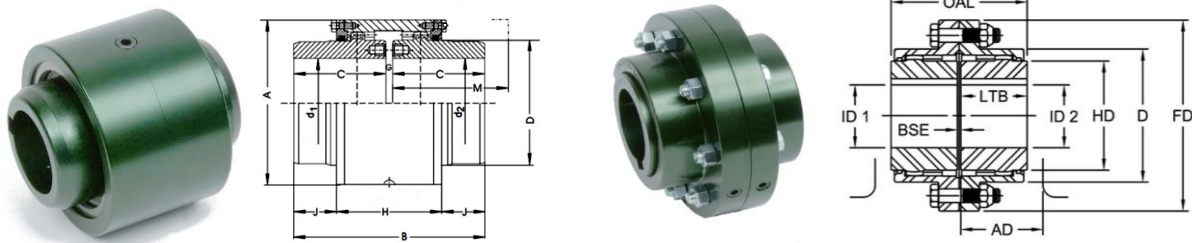

Fig. 6: a). Coupling with one-piece sleeve

b). Coupling with two-piece sleeve

In couplings with a one-piece (continuous) sleeve (Fig.6a), no bolts are required for connection. This is an advantage because it allows the coupling to be smaller and simpler. Smaller and simpler couplings have less inertia, which is advantageous during machine startup.

In couplings with a two-piece sleeve (Fig.6b), the two halves are fastened together using bolts. Bolts play a crucial role in the energy transmission process. Some coupling designs involve energy transmission through friction on the end surfaces, and in such cases, inconvenient bolts are used, requiring the bolt to provide sufficient tightening force. In other designs, bolts can be subjected to preload, and in such cases, adjustable bolts are used. Additionally, the bolts ensure the centering of the two halves of the coupling. Both cases require a thorough analysis of the repeated loading on the bolts [10],[11].

When inconvenient bolts are used, the calculation proceeds as follows [12]:

The peripheral force reduced to a single bolt is [1],:

$$F_{t1} = \frac{F_t}{z} = \frac{318310 \cdot \frac{P}{D_\mu \cdot n} \cdot K_A}{z} = \frac{318310 \cdot P \cdot K_A}{D_\mu \cdot z \cdot n} \quad [N] \quad (3)$$

$$D_\mu = \frac{2}{3} \frac{D_a^3 - D_i^3}{D_a^2 - D_i^2} \quad [mm] \quad (4)$$

$D_\mu [mm]$ – frictional diameter of the contact surfaces; $D_a [mm]$ – outer diameter of the annular surface; $D_i [mm]$ – inner diameter of the annular surface; z – number of bolts, $P [Kw]$ – power, $n [\frac{1}{s}]$ – number of revolutions. The clamping force against the slippage of a bolt is:

$$F_\mu = \mu \cdot F_b \geq S_\mu \cdot F_{t1} \rightarrow F_b = \frac{F_{t1} \cdot S_\mu}{\mu} \quad (5)$$

This force should be smaller, and this is achieved by increasing D_μ , i.e., with a narrow surface located towards the periphery of the friction plate. μ - coefficient of friction between the plates ($\mu = 0,1 - 0,2$);

S_μ - safety factor against slippage of the plates ($S_\mu = 1,2 - 1,8$)

The tightening force is:

$$F_d = F_b \cdot \xi \quad [N] \quad (6)$$

ξ_d is the tightening factor (for static loads $\xi_d = 1.5 - 2$, and for dynamic loads $\xi_d = 2 - 4$). The tightening torque of the bolt is:

$$\sigma_e = \frac{F_d}{A_1} \leq \sigma_{de} \quad [N/mm^2] \quad (7)$$

$A_1 [mm^2]$ – cross-sectional area of the core; $\sigma_{de} [\frac{N}{mm^2}]$ – allowable tightening stress of the bolt. In the case of using adjustable bolts, the calculation proceeds as follows:

The torque transmitted by the coupling is:

$$T_{max} = T \cdot K_A = 159155 \frac{P}{n} K_A = F_t \frac{D_o}{2} \quad [Nm] \quad (8)$$

The peripheral force loading the bolts due to shearing is:

$$F_t = 318310 \frac{P \cdot K_A}{D_o \cdot n} \quad [N] \quad (9)$$

D_o is the diameter of the axial circle of the bolts. Since it is difficult to adjust all screws during assembly, half of the number of bolts is taken to transmit the peripheral force (ξ_r - factor of non-uniform distribution of load, $\xi_r = 2$).

The force of one screw is:

$$F_{t1} = \frac{F_t}{z} \xi_r = \frac{2 \cdot F_t}{z} \quad (10)$$

The bolt shear stress is:

$$\tau_s = \frac{F_{t1}}{A_s} = \frac{F_{t1}}{\frac{d_s^2 \pi}{4}} = \frac{4F_{t1}}{d_s^2 \pi} \leq \tau_{ds} \quad (11)$$

d_s [mm] – diameter of the bolt shank; A_s [mm²] – cross-sectional area of the bolt shank; τ_{ds} [N/mm²] - allowable bolt shear stress; The surface pressure of the bolt shank is:

$$p = \frac{F_{t1}}{A_p} = \frac{F_{t1}}{(\delta-x)d_s} \leq p_d \quad (12)$$

x [mm] – length of the part of the thread that penetrates the flange; p_d [N/mm²] – allowable surface pressure for flange material. Gear couplings are used in: compressors, mixers, pumps, blowers and other industrial machines. Lubrication of gear couplings. There are several methods for lubricating gear couplings. Most couplings operate at speeds up to 3600 revolutions per minute or slower and use grease as a lubricant. Both greases and oils are used for lubrication at speeds from 3600 to 6000 revolutions per minute. Oil is most commonly applied as a lubricant for couplings operating at speeds above 6000 revolutions per minute. Most couplings operating at high speeds use a continuous flow of oil to provide continuous heat dissipation during coupling operation, ensuring continuous cooling. To isolate from the external working environment and prevent leakage of grease or oil for lubrication, couplings need to have seals or gaskets that also restrict the entry of dust, moisture, and other contaminants. Sleeves are equipped with lubrication fittings that allow cleaning and re-lubrication without damaging the seals. In certain cases, lubrication in couplings can be a problem. Grease has the property of separating under the action of centrifugal force, and over time, leakage may occur at the seals. If lubrication is done correctly, these couplings have a longer lifespan [13],[14].

Lubrication problems can result from one or more of the following reasons: use of an inappropriate amount of lubricant as prescribed by the manufacturer, loss of lubricant due to leakage, excessive lubrication (grease), which can hydraulically lock the coupling in position, excessive misalignment that can overheat the lubricant, use of an inappropriate type of lubricant, etc. Given the potential problems that may arise from using an inappropriate type of lubricant, it is necessary to carefully follow the instructions provided by the coupling manufacturer. It is recommended to perform lubrication and check axial movement of sleeves every 3000 hours, and to conduct alignment check of shafts, gear inspection, and seal check every 8000 hours [15],[16],[17].

Defects in gear couplings can occur as a result of human error, typically happening during design, assembly, or maintenance. Choosing an inappropriate design usually results in the use of a coupling that is either too small or intended for a different purpose. As shown in the illustration, as the misalignment between the two parts connected by the coupling increases, the contact surface decreases, leading to increased loading on the components of the coupling. This results in increased friction. This increased friction imposes a corresponding preloading on the shafts connected by the coupling. Consequently, the coupling is prevented from moving axially, and this condition is commonly referred to as coupling lock-up.

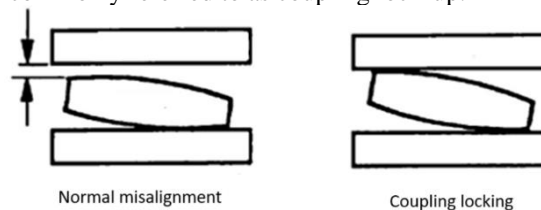

Fig. 7: Coupling Locking Due to Increased Angular Deviation

When two surfaces move relative to each other, fatigue occurs on the metal surfaces. The loading and heat generated from friction cause the metal to wear, transform, or develop cracks.

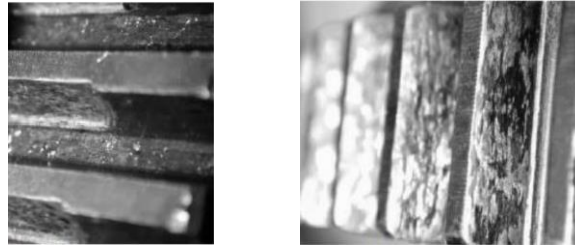

Fig. 8: Damage to the Sleeve and Hub of the Coupling

Advantages: Capable of transmitting high torque, maximum angular misalignment ranging from 0.5° to 1.5° , long operational life. Disadvantages: Requires periodic lubrication, improper lubrication contributes to increased heat and wear of components, susceptible to the effects of reverse impact during operation [18].

LATTICE COUPLINGS

Lattice couplings are very similar to gear couplings. These couplings are entirely made of metal. They have two hubs with slots instead of teeth (Fig. 9). The slots are interconnected by a steel lattice. Flexibility is achieved through the sliding movement of the lattice in the slots. The flexibility of the lattice in the curved slots provides a certain torsional elasticity. The lattice can be made from one or more parts. The cover serves to retain the lubricant in the coupling housing and can be split horizontally or vertically [19].

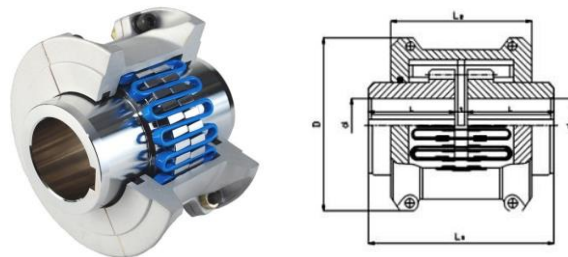

Fig. 9: Coupling with grid

Lattice couplings are used for transmitting high torque when a high degree of damping is required. Unlike gear couplings, lattice couplings have a unique ability to reduce vibrations by approximately 30%, dampening shocks from the load and thereby protecting both the drive and the working parts of the machine. However, lattice couplings have limited ability to accommodate parallel misalignment of shafts. These couplings do not transmit as much power as gear couplings (for the same outer diameter), but they are generally more cost-effective. Lattice couplings are used in medium and small-sized drives [20].

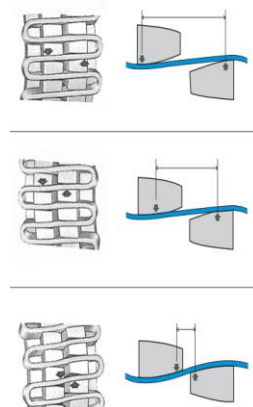

Fig. 10 : Position of the Lattice in Relation to the Loading

Easy Loading – the lattice makes contact close to the outer edges of the teeth on the hub. A wide range between the contact points remains free to flex under load.

Normal Loading – as the load increases, the distance between the contact points decreases, but there is still a free range for absorbing the load. Impact Loading – the coupling is flexible within its defined capacity. Under extreme overloads, the lattice fully supports on the teeth of the hub and directly transfers the entire load. These couplings are designed with horizontal or vertical caps (and their respective closing sets). That is the main difference between so-called horizontal and so-called vertical couplings. Other elements such as the lattice and the hub are the same in both types of couplings.



Fig. 11 : Lattice Coupling

Horizontal caps are designed for easy assembly and removal, especially in tight spaces, as they can be installed after the other elements of the coupling are in place. Vertically split caps require installation on the shafts before the hubs and lattice are installed. After the hubs and lattice are in place, vertically split caps can slide over the hubs and be secured together (this also means that for complete removal of the vertical cap from the shaft, the hubs and lattice of the coupling must be removed first). The advantage of this type of cap is that it can operate at higher speeds. Grid couplings find applications in motors, pumps, reducers, conveyors, etc. [21].

Defects in lattice couplings. Some of the common reasons that cause defects in lattice couplings are: material fatigue, overloading from torque, lack of lubrication, misalignment during operation. Fatigue from Material: Generally seen as normal wear on the coupling, fatigue appears in the form of cracks, typically in the central part of the lattice. With a few cracks, the coupling may still transmit torque with the help of the undamaged parts. However, when such a condition occurs, the coupling operates under unfavorable conditions, and it is advisable to replace the lattice as soon as possible.

Defects from Torque Overloading: Similar to those caused by material fatigue, defects from torque overloading result in cracks that appear not in the central part but towards the edges of the lattice.

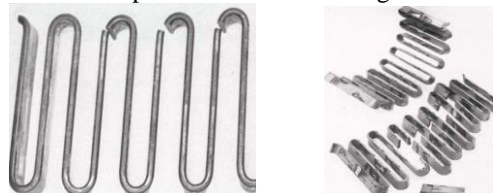

Fig. 12. Defects Arising from Misalignments and Material Fatigue

Defects arising from a lack of lubrication are often localized on one side of the grid (where lubrication is lacking) and may resemble defects caused by material fatigue. The reason for this is that in these couplings, metal-to-metal contact occurs, and the lack of lubrication will lead to premature wear of the grid wherever there is insufficient lubrication. Grid couplings are effective in dampening vibrations but are not highly adaptable to misalignments. Defects resulting from misalignments can cause the grid to break at the outer flex points. Similar to defects caused by fatigue, the coupling may still transmit torque with broken parts, but this is not a condition that can last long. The grid should be replaced promptly, and to prevent such defects, it is crucial for the shafts to be realigned and adjusted within the tolerances for misalignment of the specific coupling [22], [23].

Advantages and disadvantages of lattice coupling.

Advantages of these couplings include: Easy installation and maintenance. Simple installation and maintenance reduce labor costs and downtime. High-Quality Materials: Grids made of alloy steel and precisely machined hubs ensure superior performance and a long service life. Torsional Flexibility and Elasticity: The torsional flexibility and elasticity of these couplings help reduce vibrations and absorb shocks. Suitable for Close-Coupled Shafts: Suitable for use in machines where the shafts are closely spaced. Grid Replacement Without

Shaft Movement: When the grid needs replacement due to normal wear, it can be replaced without moving the hubs, allowing for grid replacement without relocating and realigning the machines. Disadvantages: One of the major drawbacks of grid couplings is their limited ability to accommodate misalignments. While excellent at damping vibrations, they are not designed to handle parallel misalignments of the shafts and are designed to adapt to only half the degree of angular misalignment. Additionally, maintenance can be a drawback as these couplings require periodic lubrication, which must be regularly checked and replenished with lubricant as needed.

CHAIN COUPLINGS

Chain couplings consist of identical left and right toothed hubs connected by double metal chains or acetal plastic chains. In chain couplings, similar caps to those used in other types of couplings are often employed to retain the lubricating substance.



Fig. 13 : Flexible Chain Coupling

Clutch assemblies with acetal plastic chains do not require lubrication, so caps are not needed with them. Plastic chains transmit less torque than metal chains, but they find application in environments where lubrication is considered a contaminant or where atmospheric corrosion is a concern. The chains are connected with pins. The chain is in contact with the teeth on both sprockets around their entire perimeter. The lateral spacing between the chain and the teeth allows misalignment between the connected shafts. Attachment to the shaft is usually done with screws and keyways or through fastened tapered bushings. To ensure proper functioning of the coupling, a specific distance between the leading edges of the sprockets must be maintained. To limit the torque, couplings with so-called needle bearings for reduction are available. In certain chain couplings, instead of a chain with rollers, a silent chain is used. There are two models of silent chain couplings: Straight Type Couplings: These consist of two halves divided normally along the axis of the shaft. The two halves are connected with a silent steel chain. Diagonal Type Couplings: These consist of two halves divided at an angle relative to the axis of the shaft. Due to the angular separation, the chain that wraps around the diagonal couplings is subjected to compression and tension. This results in diagonal couplings having slightly higher load-bearing capacity compared to the straight type couplings, where the chain is loaded only in shear [24],[25].

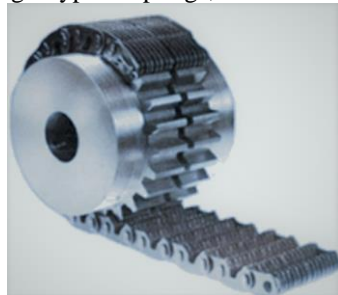

a)

Fig. 14. a) Chain Couplings -Straight Type

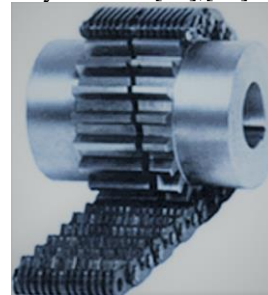

b)

b) Chain Couplings -Diagonal Type

The torque in chain couplings is calculated according to the formula:

$$T = \frac{6000 \cdot P}{2\pi \cdot n} \rightarrow T = \frac{974 \cdot P}{n} \quad (14)$$

P [kW] is power, n[1/s] number of revolutions. The speed in chain couplings is:

$$V_{\max} = R \cdot \omega \text{ [m/s]} \quad (15)$$

$$V_{\min} = R \cdot \cos \frac{\alpha}{2} \cdot \omega \quad [\text{m/s}] \quad (16)$$

$$\Delta V = V_{\max} - V_{\min} = R\omega - R\omega \cdot \cos \frac{\alpha}{2} = R\omega (1 - \cos \frac{\alpha}{2}) \quad (17)$$

$$\Delta V = R\omega \cdot \left(1 - \cos \frac{360}{z}\right) = V_{\max} \left(1 - \cos \frac{180}{z}\right) \quad (18)$$

$$\Delta V = V_{\max} \cdot \psi, \quad \psi = 1 - \cos \frac{180}{z} \quad (19)$$

ω [1/s] is angular velocity $\omega = \frac{\pi \cdot n}{30}$; n [1/min] is number of revolutions of the sprocket; z – number of teeth, R [mm] is the radius of the sprocket; V_{\max} , V_{\min} , ΔV are the maximum and minimum speed of the sprocket and their difference, ψ is the driving effect coefficient [26].

Application of chain couplings. Chain couplings are commonly used for transmission with low to moderate speed and high torque, while they are rarely applied at high speeds dominated by gear couplings and other sophisticated types of couplings. They are considered relatively robust and easy to install. Chain couplings can be used for various shaft sizes and torque capacities, with a typical bore diameter up to 88 millimeters. The allowed angular misalignment is usually a maximum of 1° , and parallel misalignment is limited to 2% of the chain pitch. Sometimes, these values are reduced for installations operating at higher speeds. These couplings are often encountered in agricultural machinery, material handling equipment, mining, light and chemical industries. Characteristic dimensions of chain couplings are shown in Fig. (15):

Bore diameter (HD): The diameter of the bore that accepts the coupled shaft.

Overall length (OL): The length from one end to the other, measured from both ends of the coupling.

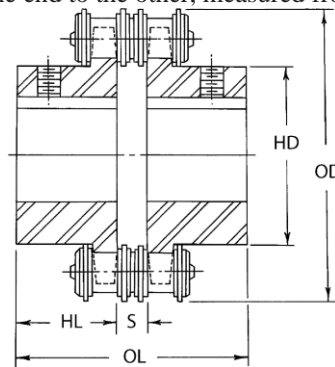

Fig. 15: Characteristic Dimensions of Chain Couplings

Coupling diameter – OD - the overall diameter of the coupling, Permissible speed – maximum number of revolutions per minute, Shaft separation - S - the space that must be maintained between the coupled shafts, Angular misalignment – represents the maximum deviation of the shaft along the radial axis that can be accommodated by the coupling, Axial misalignment – represents the maximum axial displacement along the length of the shafts

Advantages of chain couplings are: they are easy to install, have the ability to transmit high torque, feature flanges connected by double chains, providing a high level of coupling strength, can operate under unfavorable thermal and atmospheric conditions, can operate in humid environments, allow for easy disengagement of the two shafts, have high efficiency, up to 96%. Disadvantages of chain couplings are: they generate more noise compared to other types of couplings, especially those using a metal chain (plastic chains may perform less favorably than metal chains) and have a lower ability to withstand impact loads [26].

COUPLINGS WITH SLIDING BLOCKS

Flexible couplings with sliding blocks consist of identical left and right elements with openings between them where the sliding block is located (Figure 17). Couplings with sliding blocks are specially designed for machines whose shafts have parallel misalignment. Fig.17 shows a coupling with sliding blocks with commonly used ratios of characteristic dimensions for these couplings.

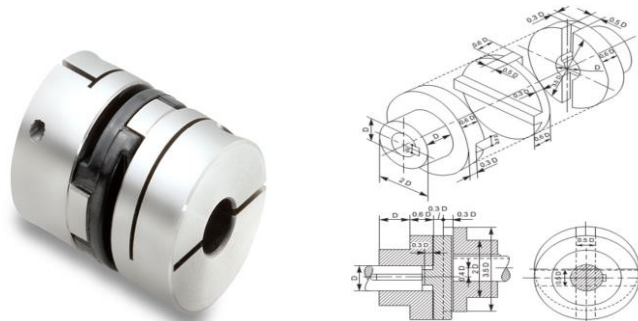
**Fig.16: Coupling with Sliding Block**

Angular misalignment, where two shafts intersect at an angle rather than a straight line, is somewhat less tolerated by this type of coupling. For transmissions that require control of movement, the sliding block is often made of a polymer such as nylon or acetal, or their combination. To minimize backlash, the sliding block is pressed between the two halves, which are often made of aluminum (or brass in smaller dimensions). Due to the sliding friction that occurs, the wear of the block contributes to a reactive force in misaligned systems. However, the block is easily replaceable, maintaining the coupling's performance. The sliding elements can be easily replaced at the coupling site. Shaft attachment is most commonly done with special clamps or sets of screws. Unlike other types of couplings that use flexible elements, couplings with sliding blocks will not continue to transmit torque in the event of a central part failure because the metal lugs on the two halves do not share the same rotation plane. This can be an advantage, as the coupling also serves as a mechanical safeguard that prevents damage to the drive or driven components in case of overload. Regular lubrication is required for proper operation of this type of coupling. The advantage of couplings with sliding blocks over other couplings is that the coupling generates very little force transferred to the bearings. In comparison to some others, these couplings have a low maximum speed, usually around 3000 revolutions per minute, although smaller couplings often can operate at higher speeds [27],[28].

The sliding speed of the cylindrical part is given by the expression:

$$v = \omega \cdot r \quad (20)$$

v [m/s] is the sliding speed of the cylindrical part; ω [1/s] is angular velocity; r [mm] is the distance between the axes of the shafts; The radial force on one side of the coupling is:

$$F_1 = \mu \frac{T}{R_{ef}} \quad (21)$$

T [Nm] is the torque being transmitted; μ coefficient of friction; R_{ef} [mm] is the effective radius

The other side of the coupling generates another radial force with the same amplitude but shifted by 90 degrees. Accordingly, the amplitude of the resultant force is:

$$F_r = \sqrt{2} \mu \frac{T}{R_{ef}} \quad (22)$$

One of the commonly used couplings with sliding blocks is the so-called Ruland couplings (named after the manufacturer). They represent a three-part assembly with a balanced design consisting of two hubs and one central disk. Ruland couplings come in sizes ranging from 3 to 30 millimeters in bore diameter.

**Fig. 17: Hub and Disk of Ruland – Coupling**

The couplings are made of aluminum with an anodized finish to improve lubrication conditions and stainless steel for corrosive applications. The hubs are manufactured through a special machining process that creates an uninterrupted interaction with the surfaces of the central disk, ensuring a long working life. The transfer of torque is achieved by connecting the openings of the central disk to the extended surfaces of the hubs. These couplings can help protect expensive machine components by limiting the torque during overloads. The disk fractures and prevents any further energy transmission. Couplings of this type are electrically insulated because the central disk is non-conductive. Ruland couplings are made from three different materials: acetal - for high torsional rigidity and zero backlash, nylon - for shock absorption and noise reduction, and PEEK - for high temperatures and low gas emission [29].

Advantages and disadvantages of couplings with sliding blocks. Advantages: Can transmit energy between non-coaxial shafts, have a low moment of inertia, the material of the central disks is plastic, meaning they are not electrically conductive, they are more economical compared to other couplings, have a high torque capacity, they are easy to assemble and disassemble. They adapt well to significant parallel misalignments – up to 10% of their outer diameter, protect the drive components and support bearings, have a compact size and easy installation, have high torsional rigidity, have the same rotational speed on both shafts, have long working life. Smaller couplings can operate at higher speeds. Disadvantages: Can only accommodate small angular misalignments, under high torque, axial loading may be transferred to support bearings, operate at a relatively low maximum speed, typically around 3000 revolutions per minute, the disk wears over time and needs replacement. If the central disk is made of metal, periodic lubrication is required due to the sliding movement of the elements.

SPIRAL COUPLINGS

Spiral couplings consist of a single piece of metal with a cylindrical shape, made flexible by removing material along a spiral path. Like all other couplings, the purpose of spiral couplings is to transmit torque between two shafts and accommodate angular, parallel, and axial misalignments between one shaft and another.

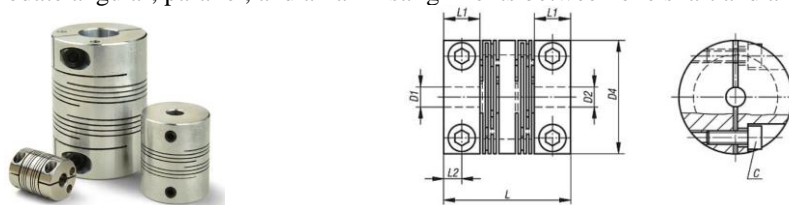

Fig.18: Spiral Couplings

These couplings differ from others in that their one-piece construction prevents backlash, which is commonly encountered in couplings composed of multiple parts. Spiral couplings are made from various materials, including titanium and acetal, with the two most common materials being stainless steel and aluminum. These couplings can connect shafts with angular misalignments of up to 90°. The performance of the coupling is determined by six main characteristics: outer and inner diameter, helix thickness, material, number of helices, and number of starts. By altering these characteristics, the capabilities for transmitting torque and accommodating misalignments can be adjusted [30].



Fig. 19 : Couplings with One and Four Spirals

There are two basic types of spiral couplings: those with a single spiral and those with multiple spirals. Both types are made from a single piece of material. Single-spiral couplings consist of a single long continuous spiral

that makes several rotations along the length of the coupling. Such couplings have excellent angular and axial flexibility but are not efficient in handling parallel misalignment. To efficiently cope with parallel misalignment, the single spiral is forced to simultaneously wind in two different directions, resulting in high stress that can cause material fatigue and eventual coupling failure. The long single spiral also has low torsional stiffness. Under the action of the load from the torque, especially during rapid accelerations or decelerations, as well as starts and stops, the coupling winds up like a spring, causing angular displacement from one end to the other, negatively affecting the accuracy of the driven part of the system. This winding results in lag in positioning the driving and driven parts of the machine while in motion. Therefore, single-spiral couplings may not be suitable for machines that require precise positioning throughout the entire movement. Torsional stiffness is also crucial for the operation of these couplings. The angular lag of the coupling may force the motor to "search" for its position, causing oscillations back and forth until the coupling reaches its original free length and the system stops. Multi-spiral couplings have a different construction compared to single-spiral couplings. They use a single or double set of spirals, unlike continuous single spirals, resulting in shorter spirals that increase torsional stiffness and positioning accuracy. The shorter the length of the spiral, the stiffer and stronger it is under torsional loads. The idea of using multiple short spirals together in one set enhances the coupling's ability to accommodate misalignments. However, such a coupling is not as flexible as a single continuous spiral coupling but has enough flexibility to be effectively used in various machines. A greater number of spirals also allows for a larger capacity to transmit torque. This type of coupling, with a set of spirals, also faces issues with parallel misalignment and quickly experiences fatigue in spirals with shorter lengths. Additional improvement in the design with multiple spirals is achieved by incorporating multiple sets with multiple spirals. Multiple-section sets allow for a greater ability to handle parallel misalignments. A coupling with a single set of sections compared to a coupling with a double set is best compared to a single universal joint versus a double universal joint. A single joint easily copes with angular misalignment but not with parallel misalignment, while the double joint easily handles both types of misalignment. Spiral couplings are used in various applications, including CT scanners, laser marking devices, 3D printers, index tables, food processing equipment, tachometers, and other instruments [31].

Material Selection for Spiral Couplings. Material selection is a crucial factor to consider when specifying a coupling. Since the coupling is made from a single solid piece of material, many of its characteristics depend directly on the type of material used. Typically, couplings are made from aluminum or stainless steel, although occasionally they may be crafted from plastic or titanium. Aluminum is commonly used for manufacturing these couplings due to its relatively low cost. It is lightweight and has an excellent strength-to-weight ratio, making it ideal for motion control systems. The low weight allows the couplings to have low inertia. The favorable strength characteristics of aluminum and its resistance to fatigue contribute to a long operational life, even under challenging working conditions. Aluminum can undergo a process called anodization, an electrolytic passivation process, to enhance its durability and corrosion resistance.



Fig. 20 : Anodized Aluminum Coupling

Stainless steel is the next most common material used in the manufacture of spiral couplings. Typically, stainless steel is chosen to increase the strength of the coupling. Stainless steel couplings are usually twice as strong as aluminum couplings with the same design and have much greater torsional rigidity. However, these couplings also have their drawbacks. Stainless steel has a mass nearly three times greater than that of aluminum, which is why this coupling has a relatively high inertia, which can reduce the system's responsiveness. Stainless steel couplings are applied in systems that operate in extreme working conditions, such as variable weather conditions, extreme temperatures, and the presence of chemicals. In addition to aluminum and stainless steel, other materials such as titanium and Delrin are rarely used to manufacture these couplings. The costs and difficulties of manufacturing couplings from these materials contribute to their application only where it is absolutely necessary to use such materials. Some advantages of couplings made of Delrin are that they have

lower mass and inertia even than aluminum and have the additional benefit of electrical insulation. However, these couplings have much lower strength and can only be appropriately applied in systems with extremely low torque requirements. A better option for systems requiring electrical insulation is to use aluminum couplings with an insulating cover [32],[33].

Advantages and disadvantages of spiral couplings. Advantages: Simple, one-piece construction, zero backlash, adaptable to all types of misalignments, balanced for higher speeds and reduced vibrations, no need for lubrication

Disadvantages: Not suitable for extreme working environments with extreme temperatures and the presence of chemicals, relatively low torsional rigidity, stainless steel couplings have greater weight, which may lead to inertia issues

BELLOWS COUPLINGS

Bellows couplings are one-piece flexible connectors used to connect driving and driven shafts in mechanical power transmission assemblies. They consist of two hubs interconnected by flexible mevo elements. Most bellow elements used in these couplings are made from one or more layers of high-quality stainless steel, alloy steel, or hydroformed sheet metal to create a corrugated surface that provides flexibility.

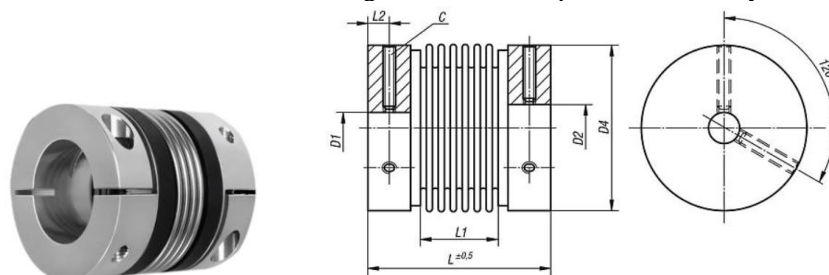

Fig. 21: Bellow Coupling

The resulting form is continuously symmetrical and very rigid concerning its rotational axis while remaining flexible in the other three axes: parallel, angular, and axial. Bellows elements are attached to the hubs by tightening, welding, or with a metallic chemical bond. During assembly, the hubs and bellows elements are mounted on a shaft whose diameter matches the corresponding diameters of the hubs, ensuring concentricity.

Typical bellows couplings can accommodate angular misalignment from 1° to 2° and parallel misalignment from 0.254 mm to 0.508 mm. They are used when precise rotation needs to be transmitted, especially at high speeds and dynamic movement. They have zero backlash and a high level of torsional stiffness. Unlike other mechanically flexible couplings, bellows couplings do not require lubrication [34].

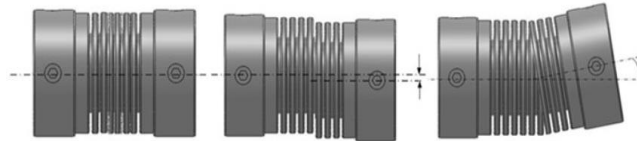

Fig. 22 : Position of the Bellow Coupling During Axial, Parallel, and Angular Displacement of the Shafts

Bellows couplings are not typically used in cases of significant shaft misalignment. During operation, they generate relatively low loads on adjacent shafts and bearings while compensating for the levels of misalignment for which they are designed. When properly aligned, usually within the range of 0.2 mm to 0.4 mm parallel misalignment, they are resistant to fatigue for an infinite operational life without the need for maintenance. However, if shaft alignment is not considered, it can lead to defects]. The torsional stiffness (C_t) in bellows couplings is given by the expression:

$$C_t = \frac{180 \cdot T}{\pi \cdot \psi} \quad (23)$$

T [Nm] – torque, ψ [rad] - angular displacement. The torque T is:

$$T = m \cdot g \cdot R \quad (24)$$

m [kg] – mass; g [m/s^2] is gravitational acceleration; R [mm] – radius. Angular displacement is:

$$\tan(\psi) = \frac{\Delta x}{\tau} \rightarrow \psi = \arctan(\Delta x/\tau) \quad (25)$$

Application of couplings with bellows. Couplings with bellows are used for:

- 1.High-precision positioning, when it comes to rotational positioning, the benefits of zero backlash and high torsional stiffness are quite evident.
- 2.High dynamic motion –the high torsional stiffness helps shorten settling times during rapid starts and stops. As a weak link in most direct drive systems, the flexible coupling determines the stiffness of the entire drive shaft.
- 3.Geometric characteristics of the coupling are of great importance when used in systems with high rotational speeds. The low weight, continuous symmetry, and uniform stress distribution enable smooth, stable operation at high speeds. Standard couplings with bellows are typically designed to operate at rotation speeds up to 10,000 revolutions per minute. Under certain conditions, by balancing the assembly, couplings can adapt and be used at much higher speeds, sometimes even exceeding 100,000 revolutions per minute.
- 4.Resistance to extreme temperatures – when machines are exposed to extreme temperatures, metal couplings are favored over elastomeric couplings because their mechanical properties remain largely unchanged even over a wide temperature range. The unique advantage of couplings with bellows is that, unlike other types of couplings, these couplings have high tolerance for axial displacement. This allows them to absorb axial displacement that may result from thermal expansion in the drive shaft and other structural changes within the machine. Couplings with bellows have wide applications in laser engraving machines, linear and ball screw actuators, tube production machines, laser cutting machines, etc. [35].

Selection of bellows couplings. Knowledge of the temperature range to which the coupling will be exposed is crucial to ensure its proper functioning. Couplings with electrodeposited bellows are typically specified to have a maximum temperature capability of 176 °C. The maximum and minimum temperatures of couplings with bellows are the main factors affecting the assembly of the spiders with the end parts of the coupling. Couplings with electrodeposited bellows are offered as soldered assemblies with a maximum working temperature of up to 148 °C or adhesive-bonded assemblies with a maximum working temperature of 115 °C. The end parts or hubs are connected to shafts, which can be of the same or different sizes. Couplings can be manufactured with various bore sizes to accommodate different shaft sizes. Additionally, the configurations of the end parts can be designed to match the specific geometry of the shafts, facilitating their assembly and enhancing the performance of the system [36].



Fig. 23: Couplings for Shafts with Specific Construction

To secure the shafts to the end parts of the coupling, screws or special tightening mechanisms are commonly used. Tightening mechanisms reduce the diameter of the end part around the shaft due to a split in the component and the fastener. Aluminum and stainless steel are the most common material choices for the end parts due to their stiffness, cost, and operational capabilities.

Advantages and disadvantages in couplings with bellows

Advantages: Operate with high precision, provide continuous speed rotation due to their symmetry, have high torsional stiffness, have high flexibility to compensate for misalignments in shafts, minimize the moment of inertia, no need for lubrication. Disadvantages: Their design may have a high manufacturing cost, when operating under conditions of maximum torque defects may occur, cracks may appear due to the thin surface of the bellows.

CONCLUSION

Gear couplings have the highest tolerance for axial movements, slider couplings perform best with parallel movements, and spiral couplings are most suitable for angular misalignments. For transmitting high torque, chain couplings are usually applied, while systems requiring vibration damping are best served by grid couplings. However, the choice of the coupling type for a specific case is influenced by a range of operational parameters. Each of the mentioned groups of couplings has its advantages and disadvantages. Depending on their construction and operating principles, some types of flexible couplings may require lubrication for proper functioning. Spiral couplings and disc pack couplings represent one-piece assemblies, and they usually do not require lubrication, as there is no metal-to-metal contact in these types of couplings. The application of flexible couplings is crucial across various industries, including compressors, pumps, generators, winches, cranes, conveyors, piston engines, copying machines, laser marking devices, as well as in the metallurgical and mining industries.

REFERENCES

- [1] Simeonov S. Goce Delcev University, Stip, Macedonia (2017) *Mechanical Elements (org.Masinski elementi)*
- [2] CM Johnson, ScienceDirect (1996), *An Introduction to flexible Couplings*, World Pump Volume 1996, Issue 363,
- [3] Wang J., Dong-Xu Li, Springer Singapore (2022) *Rigid-Flexible Coupling Dynamics and Control of Flexible Spacecraft-with Time-Varying Parameters*
- [4] R. Keith Mobley, McGraw-Hill Education (2014) *Maintenance Engineering Handbook*
- [5] Machine Design. Available online: <https://www.machinedesign.com/motorsdrives/article/21827939/flexible-couplings>
- [6] Forsthofer S.M., Elsevier Inc. (2017) *More Best Practices for Rotating Equipment*
- [7] Sekhar A.S., Prabhu B.S., Elsevier (1995), *Effects of Coupling Misalignment on Vibrations on Rotary Machinery*, Journal of Sound and Vibrations, ISSN 0022-460X, Vol.185, Issue 4
- [8] Pipe Fittings and Flanges. Available online: <http://www.thepipefittings.com/flexible-coupling.html>
- [9] Alfares M.A., Falah H.A., Elkholy H.A., ScienceDirect (2006), *Mechanism and Machine Theory*, ISSN 0094-114X, Vol.41, Issue 10
- [10] Fan W., Lu H., Zhang Y., Su X., MDPI Basel (2020), *Dynamic Characteristics of Gear Coupling and Rotor System in Transmission Process Considering Misalignment and Tooth Contact Analysis*, Processes ISSN 2227-9717, Vol.8, Issue 11
- [11] Crease A.B., ScienceDirect (1978) *Gear Couplings for High Powers and Speeds: Advantages, limitations, and alternatives*, Tribology International ISSN 0301-679X, Vol.11, Issue 1
- [12] Tyler G. Hicks, McGraw-Hill Education (2006) *Handbook of Mechanical Engineering Calculations*
- [13] Li M., Yu L., ScienceDirect (2001) *Analysis of the Coupled Lateral Torsional Vibration of a Rotor-Bearing System with a Misaligned Gear Coupling*, Journal of Sound and Vibration ISSN 0022-460X Vol.243, Issue 2
- [14] Radzevich P.S., Storchak M., Springer Cham (2022), *Advances in Gear Theory and Gear Cutting Tool Design*
- [15] Ivanova, E., Vasilev, T. (2020). *Critical Speed of Flexible Coupling - Determining with CAE Software*. In: Mitrovic, N., Milosevic, M., Mladenovic, G. (eds) Computational and Experimental Approaches in Materials Science and Engineering. CNNTech 2018. Lecture Notes in Networks and Systems, vol 90. Springer, Cham. https://doi.org/10.1007/978-3-030-30853-7_15
- [16] Coupling Tips, Design World Resource. Available online: [Types of Gear Coupling With Working Principles | Linquip](#)
- [17] Guo Y., Lambert S., Wallen R., Errichello R., Keller J., ScienceDirect (2016) *Theoretical and experimental study on gear-coupling contact and loads considering misalignment, torque, and friction influences*, Mechanism and Machine Theory, ISSN 0094-114X, Vol.98
- [18] Shah K.P. Construction, Installation and Maintenance of Flexible Couplings, Available online: <https://practicalmaintenance.net/wp-content/uploads/Construction-Installation-and-Maintenance-of-Flexible-Couplings.pdf> (slika 7)
- [19] Budynas R, Nisbett K., McGraw-Hill: New York, NY, USA, (2014). *Mechanical Engineering Design*
- [20] Prodanescu G.S., Iliuc I., RO116430

- [21] Jazar N.R., *Advanced Vibrations, Theory and applications*, Springer Cham (2023)
- [22] Coupling Answers. Available online: <http://www.couplinganswers.com/2014/12/why-grid-coupling-features-benefits.htm> (slika so pruzina)
- [23] Donghai Hu, Bifeng Yin, Springer Singapore (2022), *Stability Analysis and Control of Powertrain for New Energy Vehicles*
- [24] Dodge Industrial, Inc. Available online www.dodgeindustrial.com, https://tt-net.tsubakimoto.co.jp/tecs/pdct/kcp/pdct_cr.asp (chain couplings)
- [25] *Innovation in Motion. Tsubaki*. Available online: https://tt-net.tsubakimoto.co.jp/tecs/pdct/kcp/pdct_cr.asp [chain couplings]
- [26] Dieter G., Schmidt L., McGraw-Hill Education, New York NY, USA (2012) *Engineering Design*, 5th Edition
- [27] The Lovejoy Coupling Handbook. Available online: <https://www.lovejoy-inc.com/resources/the-lovejoy-coupling-handbook/>
- [28] R. Keith Mobley, Butterworth-Heinemann (2001) *Plant Engineer's Handbook*
- [29] Schneider H., *Rotor Balancing*, Springer Vieweg Berlin, Heidelberg (2023)
- [30] Piotrowski J., CRC Press (2006) *Shaft Alignment Handbook (Mechanical Engineering)*
- [31] Thomas Xometry. Available online: [All About Oldham Couplings - Attributes and Specifications \(thomasnet.com\)](http://www.thomasnet.com)
- [32] Ruland RM. Available online: <http://www.ruland.com/technical-resources/technical-articles/technical-article-beam-coupling>
- [33] Tuckmantel, F.W.S., Schoola, C.G., Cavalca, K.L. (2019). *Flexible Disc Coupling Model in Rotating Shafts*. In: Cavalca, K., Weber, H. (eds) *Proceedings of the 10th International Conference on Rotor Dynamics – IFToMM . IFToMM 2018. Mechanisms and Machine Science*, vol 61. Springer, Cham. https://doi.org/10.1007/978-3-319-99268-6_35
- [34] Hefazi H., Grote K-H., Springer Cham (2021) *Springer Handbook of Mechanical Engineering*
- [35] Sclater N., McGraw-Hill Education (2011) *Mechanisms and Mechanical Devices Sourcebook*, 5th Edition
- [36] Rajagopalan K., Springer Singapore (2022) *Torsion of Thin Walled Structures*